



The Next Generation of Jandy Pumps

Providing superior performance and efficiency while incorporating "Quiet Technology," Jandy's newly re-designed Stealth takes our pumps to the next level. The new Stealth boasts an even larger trap basket, making it the largest in the industry. It is designed for trouble-free installation and maintenance, offering the most efficient single and two speed pumps. Stealth pumps will easily operate all of your pool and spa needs.



QUIET TECHNOLOGY



Jandy's line of Stealth pumps incorporate "Quiet Technology" into every pump. This proprietary design controls the flow dynamics within the pump, resulting in less noise and quiet operation.

LARGE CAPACITY BASKET



Our basket is the largest trap basket in the industry. It fully maximizes the hydraulic flow by holding more debris and is easy to maintain. The Jandy Stealth pump requires less maintenance.

PERFORMANCE



The impeller and diffuser provide the highest performance and efficiency levels. Jandy's proprietary design makes the Stealth the most efficient single speed pump available.

ENERGY EFFICIENT MOTOR



The Stealth pump is powered with an energy efficient motor that saves up to 20% on energy costs. The back plate design makes it easy to maintain and service.



Stealth Pumps – Quiet, Powerful, Efficient

Jandy's premium line of Stealth pumps are Quiet, Powerful and Efficient. They boast the largest basket capacity in the industry. Jandy Stealth pumps give you the high performance power required to drive in-floor cleaning systems, spas, and water features while being the most efficient single speed pumps available. They are the perfect choice for your pool, spa, or water feature pumping needs.

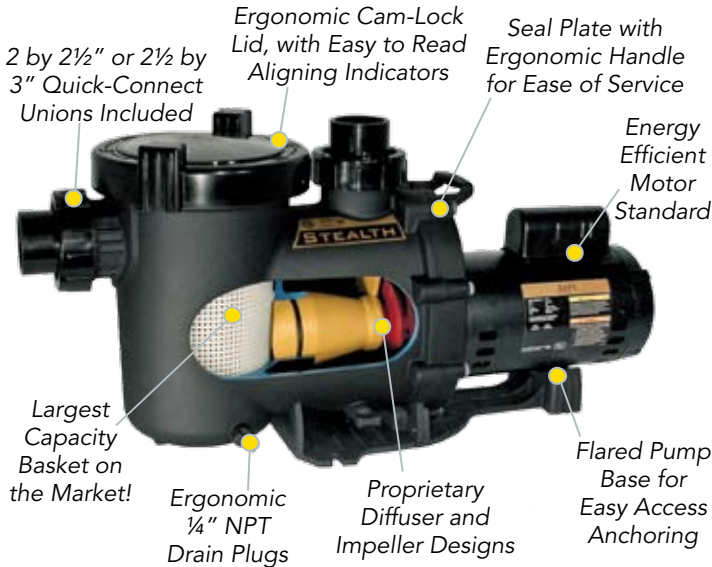

STEALTH PUMP DIMENSIONS

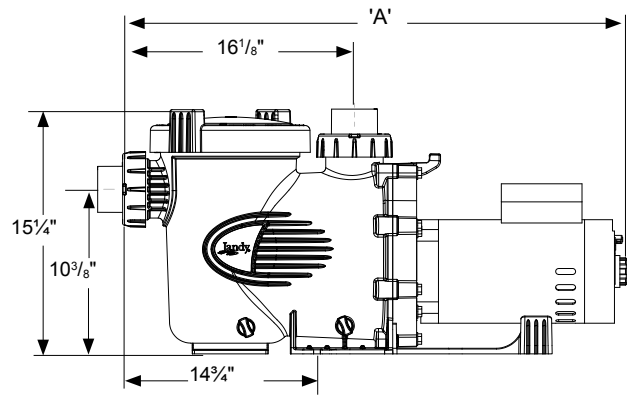

Front Edge of Union to Center of Bolt Holes



Pump with Sweep Elbow
p/n SEAQL1001

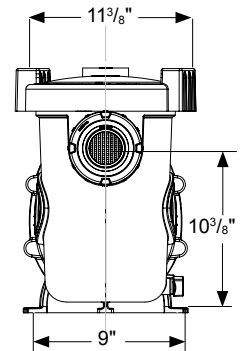

Bolt Holes, Center to Center

PERFORMANCE

STEALTH PERFORMANCE CURVES

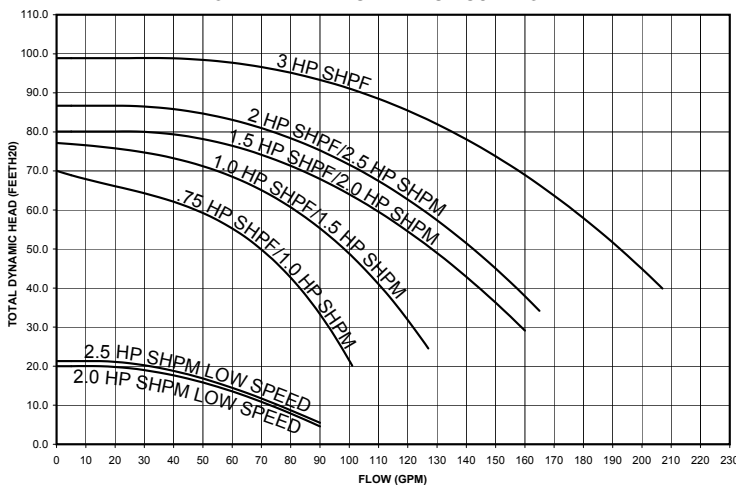

Specifications for Jandy SHPF/SHPM Pumps

Model No.	HP	Voltage	Amps	Pipe Size	Carton Weight	Overall Length 'A'
SHPF.75	.75	208-230/115	6.0-5.6/11.2	2-2½"	43 lbs.	31⅞"
SHPF1.0	1.0	208-230/115	7.8-7.4/14.8	2-2½"	45 lbs.	32¼"
SHPF1.5	1.5	208-230	9.6-8.8	2-2½"	50 lbs.	32⅝"
SHPF2.0	2.0	208-230	11.0-10.0	2-2½"	57 lbs.	33⅛"
SHPF3.0	3.0	208-230	15.0-13.6	2½-3"	68 lbs.	33⅛"
SHPM1.0	1.0	208-230/115	6.0-5.6/11.2	2-2½"	43 lbs.	31⅞"
SHPM1.5	1.5	208-230/115	7.8-7.4/14.8	2-2½"	45 lbs.	32¼"
SHPM2.0	2.0	208-230	9.6-8.8	2-2½"	50 lbs.	32⅝"
SHPM2.5	2.5	208-230	11.0-10.0	2-2½"	57 lbs.	33⅛"
SHPM2.0-2	2.0	230	10.0/3.5	2-2½"	57 lbs.	32⅝"
SHPM2.5-2	2.5	230	11.0/4.0	2-2½"	64 lbs.	33⅛"



ALL JANDY PRODUCTS WORK SEAMLESSLY TOGETHER

Jandy Control Systems manage our complete line of technologically advanced products.



Pumps • Filters • Heaters • Air Energy Heat Pumps
Controls • Lights • Water Purification Systems • Valves
Water Features • Cleaners • Accessories



L0973A